

## MINIBAR TOP A+ 28 Lt.

Minibar for hotels with high energy efficiency (ex class A +), built-in or free-standing.

Innovative thermoelectric cooling system, based on a solid state heat pump (cell of Peltier). **Completely noiseless** (zero db) and **ecological** (absence of ammonia).

### Other features:

- Built-in / free standing
- Electronic thermostat
- Electronic autodefrost
- Low consumption LED inside
- Reversible door
- Suitable for 1lt. and 1,5 lt. bottles
- Sliding hinge fixture
- R600a cooler
- COMPLETELY NOISELESS, CERTIFIED by SG



Color	Black (PVC)
Installation type	Recessed or free installation
Energetic class	E (ex class A+)
Refrigerated volume	25 lt.
External dimensions (H x W x D)	475 x 385 x 385 mm
Net weight	10,1 Kg
Voltage	230 V
Frequency	50-60 Hz
Rated power	63 W
Daily consumption	0,285 kWh/24
Yearly consumption	78 kWh
n ° adjustable internal shelves	2
Pcs per box	Single
Packaged dimensions (H x W x D)	540 x 440 x 440 mm (excluded pallet)
Packaged weight excluded pallet	11,2 Kg
Packaged volume excluded pallet	0,10 mc
Measure master carton (H x W x D)	50 x 50 x 65 cm (included pallet)
Weight included pallet	14,2 Kg
Volume included pallet	0,16 mc
Pcs per pallet	18 pz.

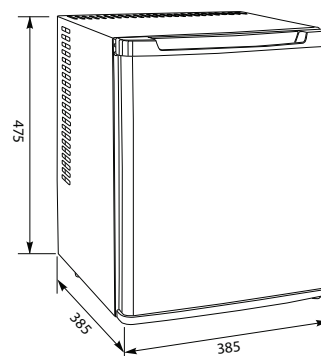

Article	Description
TOP A+ 28	Recessed or free standing 28 Lt. minibar